



Reinforced angle brackets are suitable for structural applications in framing and wood-frame houses.



[UK-DoP-e06/0106](#)
[ETA-06/0106](#)

FEATURES



Material

- Pre-galvanised mild steel.

Benefits

- Load capacity in all directions
- Improved capacities for full and partial nailing

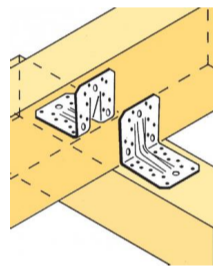
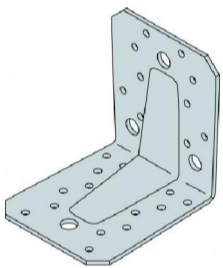

APPLICATIONS

Suitable On

- **Supporting member:** solid wood, glued-laminated wood, concrete, steel, etc.
- **Supported member:** solid wood, composite lumber, glued-laminated wood, triangular trusses, profiles, etc.

When to Use

- Fastening of small trusses.
- Cladding plates, cladding uprights.
- Rafter anchors, cantilevers, headers, etc.

TECHNICAL DATA

Dimensions

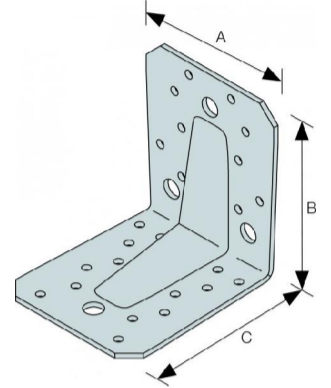
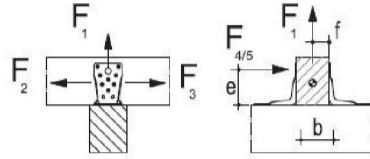
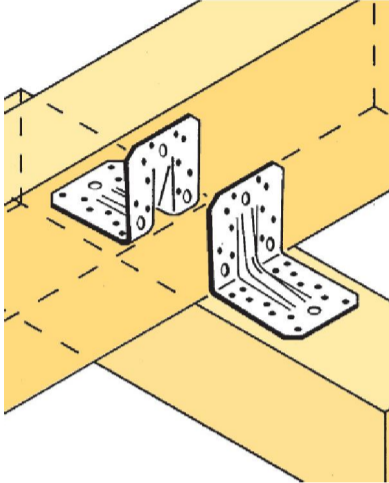

References	Dimensions				Holes leg B		Holes leg C	
	A	B	C	t	nails or screws	bolts	nails or screws	bolts
ABR105-R	90	105	105	3	14 $\varnothing 5$	1 $\varnothing 11$	10 $\varnothing 5$	3 $\varnothing 11$

Wood/wood connection beam/beam type - assembly with 2 angle brackets

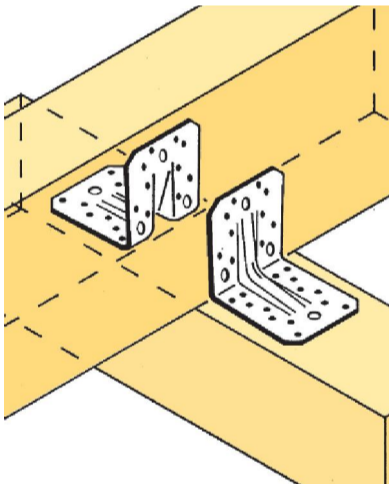

References	Fixing		Characteristic Values			
	leg B	leg C	Tension (F1)		Shear (F2=F3)	
			CNA4.0x35	CNA4.0x50	CNA4.0x35	CNA4.0x50
ABR105-R	14	10	8.9	14.3	13.6	19.1

INSTALLATION

Fixing

On wood:

- CNA annular ring-shank nails dia. 4.0 x 35 or dia. 4.0 x 50 mm.
- CSA screws dia. 5.0 x 35 mm or CSA screws dia. 5.0 x 40 mm.
- Bolts.
- LAG screws.

On concrete:

Concrete substrate

- Mechanical anchor: WA M10-78/5 OR WA M12-104/5 pin.
- Chemical anchor: AT-HP resin + LMAS M10-120/25 or LMAS M12-150/35 threaded rod.

Hollow masonry substrate:

- Chemical anchor: AT-HP or POLY-GP resin + LMAS M12-150/35 threaded rod + SH M16-130 screen.

On steel:

- Bolts.

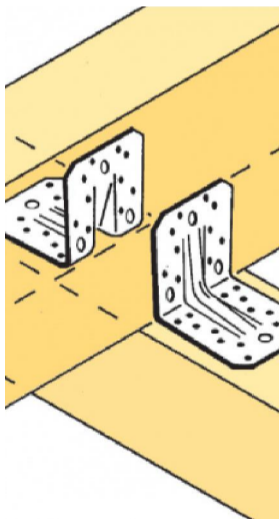

TECHNICAL NOTES

Technical Info

F1: tensile force in the central axis of the angle-bracket

Particular situation of a fastening with only one angle-bracket:

- If the overall structure prevents the rotation of the purlin or the post, the tensile strength is equal to half of the given value for two angle-brackets.
- Otherwise, the connection resistance depends on the « f » distance between the vertical contact surface and the point of load application.

F2 and F3: shear lateral force

Particular situation of a connection with only one angle-bracket:

- The resistance value to consider is equal to half of the one given for two angle-brackets.

F4 and F5: transversal force directed towards or opposite the angle-bracket

- The connection resistance depends on the « e » distance between the base of the angle-bracket and the point of load application.
- To consult corresponding loads, contact us.

Only F1, F2 and F3 forces for connections with 2 angle-brackets are present on this sheet.
For more information, contact us.